



For Earth, For Life
Kubota

SVL

KUBOTA COMPACT TRACK LOADER SVL95-2S

Kubota's Compact Track Loader delivers the power and comfort you need to achieve extraordinary levels of performance and productivity.

The power and comfort to get the job done right.

With best-in-class bucket breakout force and lifting capacity, outstanding stability, and a wide and comfortable operator area, Kubota's new SVL95-2S Compact Track Loader delivers extraordinary levels of performance, reliability, and comfort.

Outstanding Performance

Load sensing system

The SVL95-2S' load sensing system ensures the optimal flow rate for each attachment as well as increases power by 3 HP, letting you get the job done quickly and efficiently.

Model	SVL95-2S	
Engine(Net)	96.4 HP (71.9 kW)	
Rated operation capacity 35% tipping load	3200 lbs (1451 kg)	
Breakout force	Bucket	7961 lbs (3611 kg)
	Lift arm	6742 lbs (3058 kg)

Enhanced AUX flow rate

The SVL95-2S offers a significantly enhanced AUX flow rate, allowing you to take advantage of high-efficiency attachments that require a large flow rate.



Aux. hydraulic flow	Std.	23.1 gpm (87.6 lpm)
	High	40.0 gpm (152 lpm)

Adjustable AUX flow

Quick and easy 14-step adjustment of the AUX flow ensures the optimal flow rate for every job you do.

Exceptional Comfort

Enhanced A/C

Enjoy outstanding cooling and heating performance and supreme comfort year-round, thanks to the A/C with optimized airflow.

Engine dial throttle

Change the engine speed setting with a quick twist of the conveniently located dial throttle.

Operator comfort

A new safety bar increases operator space. Foot space also has been increased.



Radio ready

Features

Final Tier4 engine

An SCR system helps the SVL95-2S meet Final Tier4 requirements. A quick glance at the digital panel tells you how much AdBlue (DEF) remains in the tank and also when to refill it.



Specifications

Model		SVL95-2S		
Type of operator station		Closed CAB		
Engine	Model	V3800-TIEF4		
	Gross HP	HP (kW)/rpm	96.4 (71.9)/2400	
	Displacement	cu.in. (cc)	230.0 (3769)	
	Cylinders	4		
	Bore × Stroke	in.(mm)	3.94 (100) × 4.72 (120)	
	Aspiration	Turbocharged		
Loader Performance	Rated operating capacity-35% tipping load		lbs. (kg)	3200 (1451)
	Tipping load		lbs. (kg)	9143 (4147)
	Breakout force	Bucket	lbs. (kg)	7961 (3611)
		Lift arm	lbs. (kg)	6742 (3058)
	Lift arm path		Vertical	
Undercarriage	Track Width	Standard	in. (mm)	17.7 (450)
	Ground pressure		psi	4.4 / 4.5
	Track rollers (per side)		5	
	Track ground contact length		in. (mm)	65.6 (1667)
	Travel speed	Low	mph (km/h)	5.0 (8.0)
		High	mph (km/h)	7.3 (11.7)
	Traction force		lbs. (kg)	12178 (5524)
Min. ground clearance		in. (mm)	11.5 (293)	
Hydraulic system	Aux. hydraulic flow	Std./High	gpm (ℓ/min.)	23.1 (87.6) / 40.0 (152)
	Aux. hydraulic pressure		psi (kgf/cm ²)	3553 (249.8)
Service refill capacities	Hydraulic system		gal. (ℓ)	17.96 (68)
	Hydraulic tank		gal. (ℓ)	10.1 (38.1)
	Fuel tank		gal. (ℓ)	28.8 (109)
	Off tank		gal. (ℓ)	5.0 (18.8)
Operating weight (Includes operator weight 165lbs.)		lbs. (kg)	11574 (5250)	

Dimensions

A	Length of track on ground	in. (mm)	65.6 (1667)
B	Track gauge	in. (mm)	59.5 (1512)
C	Length w/o bucket	in. (mm)	123.5 (3137)
D	Length w/bucket on ground	in. (mm)	154.6 (3929)
E	Height to top of cab	in. (mm)	83.3 (2116)
F	Bucket hinge pin height at max. lift	in. (mm)	128.5 (3264)
G	Rollback angle at carry position	degree	27
H	Reach at max. lift and dump	in. (mm)	40.7 (1035)
I	Ground clearance	in. (mm)	11.5 (293)
J	Departure angle	degree	31
K	Max. dump angle	degree	43
L	Vehicle width Narrow Track / Std Track	in. (mm)	77.2 (1962)
M	Width with bucket	in. (mm)	80 (2032)
N	Turning radius from center-machine rear	in. (mm)	127 (3220)

The company reserves the right to change the above specifications without notice. This brochure is for descriptive purposes only. Please contact your local Kubota dealer for warranty information. For your safety, Kubota strongly recommends the use of a Rollover Protective Structure (ROPS) and seat belt in almost all applications.

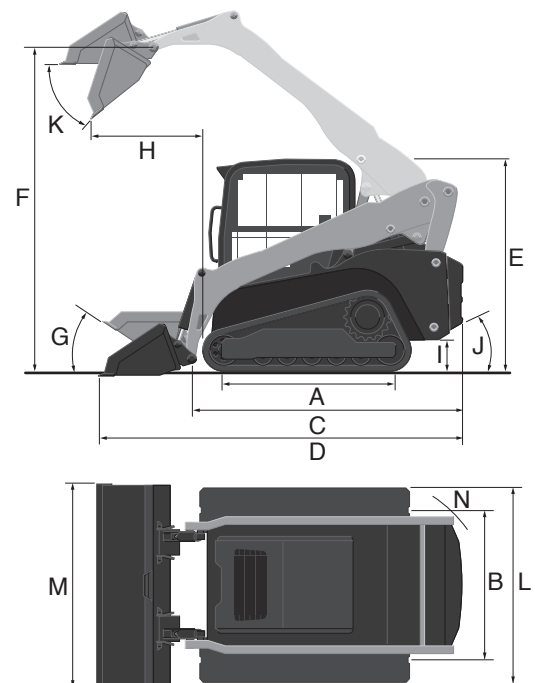

©2016 Kubota Corporation



KUBOTA Tractor Australia Pty Ltd

25-29 Permas Way, TRUGANINA Vic, 3029
 Freecall: 1800 334 653
 Email: sales@kubota.com.au

Web Site: <http://www.kubota.com.au>

CB Norwood Distributors Ltd

PO Box 1265, 888 Tremain Avenue,
 Palmerston North 0800 KUBOTA
 Tel: 06 356 4920 Fax: 06 356 4939

Web Site: <http://www.kubota.co.nz>